

Content

“Will You Go?”
by Pastor Colin Wong



Missions Support



Missions Events
in the coming months



“Will You Go?” - Pastor Colin Wong

Is God interested in missions today? Has He revealed in His Word that “missions” is His will for His people? If we really believe in the God of missions, then why are we not embarking on mission trips? What is holding us back?

Paul said, “How then shall they call on him in whom they have not believed? and how shall they believe in him of whom they have not heard? and how shall they hear without a preacher? And how shall they preach, except they be sent? as it is written, How beautiful are the feet of them that preach the gospel of peace, and bring glad tidings of good things!” (Romans 10:14, 15) My purpose of writing this article is to impress upon you that our God is the God of missions and hopefully you will prayerfully consider going on a mission trip to Cambodia, Indonesia, Thailand, Myanmar or Africa.

The First Call

God is our first missionary. One of the major themes in the Bible is God's missionary plan for the lost world. We see it clearly demonstrated in the book of Genesis. God created man and woman and placed them in the Garden of Eden (Genesis 1, 2). When our first parents disobeyed God by disobeying His command (Genesis 2:16, 17; 3:6), they were cast out of the Garden of Eden. They no longer enjoyed the sweet fellowship they had with God (Genesis 3:8). But God, despite man's disobedience, had a wonderful plan – a plan to save the fallen race. Genesis 3:15 is said to be the first Pronouncement of the Gospel [*protoevangelium*] (Romans 16:20).

In the Gospels, we read about God's missionary plan. In John, we have the declaration of God's love for the world (John 3:16). In Luke, we have the record of the purpose of Jesus' coming – "*He came to seek and save the lost*" (Luke 19:10). In Matthew, we have the missionary purpose of Jesus – "He came to save his people from their sins" (Matthew 1:21). In John, we have the urgency to preach the Gospel – "*Say not ye, There are yet four months, and then cometh harvest? behold, I say unto you, Lift up your eyes, and look on the fields; for they are white already to harvest*" (John 4:35). In Acts we are told to go to the regions beyond (Acts 1:8; Romans 15:20).

Throughout the Bible God has made known His mission to His people. In fact, the Bible begins, ends and revolves around this great theme: "*Our God is a missionary God and His purpose is to purchase and restore to Himself a people from every nation to be gathered before the King of all ages*" (Revelation 5:9, 10; 19:7).

The living God is indeed a missionary God. His heartbeat is missions. His missionary purpose is found everywhere in the Bible. We shall begin with Noah, the preacher of righteousness.

The Call of Noah

The call of Noah to missions is found in Genesis 6. This chapter depicts man's wickedness, God's judgment upon man's wickedness and God's command to Noah to build an ark. In the time of Noah, God saw man's wickedness on earth and that every inclination of the thoughts of his heart was only evil all the time. God was very grieved that He had created man and His heart was filled with pain. So He decided to destroy mankind, animals, creatures and birds of the air. However, one man found favor in His eyes. His name was Noah. He was a righteous man, blameless among the people of his time, and he walked with God (Genesis 6:5-9).

In Genesis 6:13-15 we find God warning Noah, telling him to escape the coming judgment. He commanded him to build an ark, giving him the plan of the ark. And Noah did everything just as God commanded him (Genesis 6:22). The writer of Hebrews tells us that "*By faith Noah, being warned of God of things not seen as yet, moved with fear, prepared an ark to the saving of his house; by the which he condemned the world, and became heir of the righteousness which is by faith*" (Hebrews 11:7).

A striking parallel is the Second Coming of Christ. Jesus says in Matthew, "*But of that day and hour knoweth no man, no, not the angels of heaven, but my Father only. But as the days of Noe were,*



so shall also the coming of the Son of man be” (Matthew 24: 36, 37). What were the days of Noah like? “For as in the days that were before the flood they were eating and drinking, marrying and giving in marriage, until the day that Noe entered into the ark, And knew not until the flood came, and took them all away; so shall also the coming of the Son of man be” (Matthew 24:38, 39).

There is a striking parallel between the normality of life upon the earth before the flood came and the normality of life just before Jesus comes. Just as life was going along in an unbroken line when the flood came, so life will be going on in an unbroken line when the Second Coming of Christ will occur.

Despite man’s wickedness and his rejection of God, Peter speaks about the longsuffering of God. He tells us that God is not willing that any should perish but that all should come to repentance (2 Peter 3:9). Again he says, *“And [God] spared not the old world, but saved Noah the eighth person, a preacher of righteousness, bringing in the flood upon the world of the ungodly”* (2 Peter 2:5; 1 Peter 3:20). Noah was a preacher of righteousness. He did not just build an ark in faith; he also preached righteousness. He preached against the people’s wickedness. How long did he preach? He preached for 120 years. How many souls were saved? There were only eight souls saved from the flood.

To me, this clearly depicts God as a God of missions. God warned Noah that He would send a flood to destroy the whole world. And yet at the same time, He sent preacher Noah out to warn the people about the coming flood and exhort them to repent from their wickedness.

What is the lesson for us? We are to do likewise – that is to go and warn the unsaved of the impending judgment of God.

The Call of Abraham

The missionary purpose of God is also demonstrated in the life of Abraham or more accurately, Abram as he was called at that time. Four thousand years ago, God called Abram to leave his country, loved ones and house to a land that he would show him. That account of God’s call to Abram is found in Genesis 12:1-4.

God made a promise to Abram. In it, there are three promises given to him for obeying his call from God to leave his country, loved ones and house. First, God would make him a great nation. Second, God would bless him abundantly. And third, God would make his name great. However, there are three conditions that he had to fulfill before he could see these promise fulfilled in him – 1) To leave his country, 2) To leave his loved ones, and 3) To leave his house.

The call of Abram was a call to salvation. First, God called him to leave his country. The reason is that moon worship was the dominant cult in Ur and Haran. Abram was born in Ur of the Chaldees. And most probably he was an idol worshipper. His father Terah took him to Haran, a place of idolatry. And there, God called him to leave his country. Second, God called him to leave his loved ones. The reason is all his loved ones were idol worshippers. Foreign gods were among the belongings that Jacob’s family took with them from Haran to Bethel (Genesis 35:2), and the same was true of those who gathered at Shechem under Joshua. Religious practices were persistent, and some



of the Israelites who entered Canaan with Joshua were still clinging to the gods their fathers served “*beyond the River*,” that is, in Mesopotamia, beyond the Euphrates (Joshua 24:14, 23). Therefore, the break with his loved ones would set him free from the influence of ancestral traditions that could be harmful and detrimental to him. And finally, God called him to leave his house. Why? Being born in an idolatrous family, foreign gods were often found in the house. For that reason, God did not want him to have anything to do with them.

Abram had heard the call of God but his knowledge of him was limited. Without the break with the past, there would be no further revelation. In a similar way, Jesus called his disciples to “*leave their nets*” and follow Him (Mark 1:17, 18). Elsewhere Jesus compared His love with the love of others (Luke 14:26). This also applies to us who want to follow Jesus. We have to abandon the past, make an about turn and start afresh in the service of God. Like the Thessalonians, we are to turn from idols to serve the living and true God (1 Thessalonians 1:9). Although our circumstances may not be the same as Abram, nevertheless to forsake all in order to serve God is as decisive a step as was Abram’s move from Haran to an unknown place (Matthew 6:24).

The call of Abraham was a call of blessing. God promised to make Abraham a great nation. Later God changed his name from “*Abram*” (“*exalted father*”) to “*Abraham*” (“*father of a multitude*”) because He said that He would make him the father of many nations (Genesis 17:5).

But before Abraham could become a father of many nations, he needed to become a child of God. On what basis did God accept him? The story is told in Genesis 15. God promised Abraham a son in his old age. He brought him out in the open field and asked him to look to the sky and count the stars. He tried but soon gave up. It was an impossible task. Then God said to him, “*So shall thy seed be*” (Genesis 15:5). Though he and his wife Sarah were beyond childbearing, he

did not waver at God’s promise through unbelief, but was strong in faith, giving glory to God (Romans 4:20). As a result, God accepted him as righteous in His sight. In New Testament language, he was justified by faith (Romans 4:2, 3).

When Paul discussed the subject of Justification by Faith, he used Abraham as an example (Romans 4). Abraham was declared righteous in the sight of God apart from good works; so also those who have trusted Christ by faith for salvation have also become Abraham’s seed and heirs according to the promise (Galatians 3:26, 29).

God is the God of missions. If God has promised to bless “*all the families of the earth*,” He has promised to do so “*through the seed of Abraham*” (Genesis 12:3; 22:18). Now we are Abraham’s seed by faith (Galatians 3:29), and the families of the earth will be blessed only if we go to them with the Gospel of salvation.

The Call of Jesus

From eternity God had in mind the work of Calvary. In his appointed time, Jesus came down, earth to trod so that sinners might live again in the image of God (John 1:14; Matthew 1:21; Galatians 4:4). We are told that Jesus came not to be served but to serve and to give His life a ransom for many (Mark 10:45). He came to do God’s will (John 4:34; Hebrews 10:7). Therefore, He was willing to lay down His life for the sheep (John 10:11, 15). In His high priestly prayer, He prayed for those whom God has given Him (John 17:9).

In His post-resurrection appearance, He said to His disciples, “*...as my Father hath sent me, even so send I you*” (John 20:21). God the Father is a missionary God. God the Son is a missionary God. And God the Holy Spirit is a missionary God (Acts 13:2, 4). The Triune God is a missionary God.

The Call of Paul

Before Paul became a Christian, he was a persecutor of the church (Acts 8:58; 8:1; 9:1, 2; Galatians 1:13, 14). On his way to Damascus to persecute Christians, Paul met Jesus at noonday. Immediately, he cried out to Him, “*Lord, what wilt thou have me to do?*” (Acts 9:6) Jesus replied, “*But rise, and stand upon thy feet: for I have appeared unto thee for this purpose, to make thee a minister and a witness both of these things which thou hast seen, and of those things in the which I will appear unto thee; Delivering thee from the people, and from the Gentiles, unto whom now I send thee, To open their eyes, and to turn them from darkness to light, and from the power of Satan unto God, that they may receive forgiveness of sins, and inheritance among them which are sanctified by faith that is in me*” (Acts 26:16-18).



He told the elders of the church in Ephesus that nothing would distract him from giving of his best to the Lord to fulfill the mission that God had entrusted to him (Acts 20:24; 2 Timothy 4:7, 8). Paul never forgot his call to missions. He went everywhere preaching the Gospel despite persecution and afflictions (Romans 15:20).

The Call of Christians

Every Christian is a witness for Jesus Christ (Mark 16:15). The Great Commission is for Christians (Matthews 28:19). God saves us and commissions us to be his witnesses (John 20:21). He will empower us to do his work (Acts 1:8).

We are to be world Christians (not worldly Christians). Christians are called to become global Christians with a global vision, for we have a global God. Like Paul, Christians would go into places where Christ is not made known. To the regions beyond! Christians must go and proclaim this glorious, eternal Gospel to the unsaved while awaiting the coming of the Lord (Luke 19:13).

Will **YOU** go, even to the regions beyond? (Isaiah 6:8) Amen.

Lovingly in Christ,
Pastor Colin



Missions Supports

Kenya

With the return of our sister Pui Meng, the Kiluani medical ministry was handed over to Rev Mark Kim of Bible College of East Africa. This eventually closed due to a lack of volunteers, leaving a balance of \$24,900 in the “Kenya Medical Missions Fund.” Part of this sum of \$24,900 had been used to purchase de-worming medicines for Bible school students. Recently, the Missions Committee had been sourcing for another worthy medical cause in Kenya that this fund could be used for, through sister June Tan. Through her contact, we came to know of a Rev Tanui who is in urgent need of \$16,000 to see him through a kidney transplant operation.



Rev Tanui, with whom our sister June Tan had served together at Bomet Bible Institute, is currently the pastor of Cheikeliek Africa Gospel Unity Church. He further leads a group of 15 churches as moderator. Our sister June Tan had found him to be a dedicated and persevering minister of God.

The Missions Committee, with Session’s approval, decided to support this worthy medical cause as an indirect way of extending the works of the gospel in Kenya.

Cambodia

Rev Moses Hahn of Kompong Som Bible School (KBS) made a request to Missions Committee for financial support towards the purchase of a new truck.

KBS had been using a 1998 truck to ferry some 60 – 70 children from Ottreth to KBS to have lessons on week days. This old truck was too small for such a large group of children and posed safety issues while ferrying them to and from the church. Besides, the reliability of this truck was also suspect due to its age and excessive wear and tear; hence, the need for a newer and bigger truck.

On the basis of the children’s safety, the Missions Committee, with approval from Session, decided to support KBS towards the purchase of a 2003 Hyundai truck as shown in the pictures.



Batam - Hidup Baru Batu Aji School

This school, which was founded by sister Roska, is located at the same premises as Batu Aji B-P Church. It has been in the ministry of providing good Christian education for children from mostly needy families for more than 15 years. The vision of the school is that every student will know Christ personally and live a new life ('hidup baru') in Christ.

Though the present enrolment is more than 400 students, there are only 6 classrooms, an office and a teachers' room. Despite the cramped conditions the school has produced students who have excelled in mathematics for many years.

As the present school buildings are wooden structures, they have become worn and weathered with use (see photos). If nothing is done, they will deteriorate further and become unsafe for the students to use. Because of the urgency of the situation sister Roska started to build 2 new classrooms behind the existing structures. Her plan is to add another 2 classrooms on top of the 2 currently being constructed, making a total of 4 new classrooms eventually. However, she is in need of funds to see her through the project and has therefore approached Missions Committee for a \$60,000 loan – the total costs of the construction project.



On the basis of the children's safety and their needs of a more conducive environment, Missions Committee, with the approval of session, decided to extend this loan to sister Roska repayable over a 7-year period.



Church members are welcome to make contributions toward this project and your offerings will help to lower the loan quantum and shorten the repayment period.

Please designate your offering to "Batu Aji Building Fund".

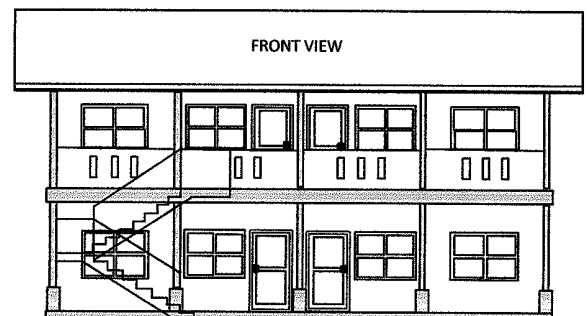
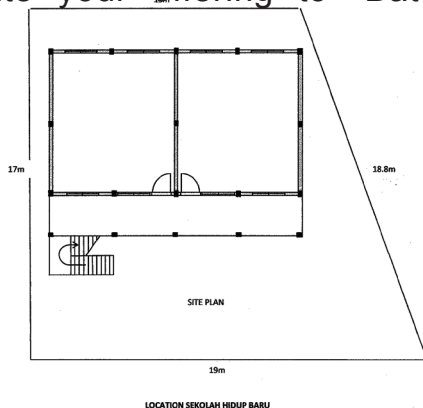

Missions Events in the Coming Months

July 3

Pastor Colin Wong administers Holy Communion to churches in Batam.

August 7

Pastor Charles Seet administers Holy Communion to churches in Batam; Ladies Sunday School class mission trip to Batam.

September 4

Pastor Quek Keng Khwang administers Holy Communion to churches in Batam.

October 2

Pastor Charles Seet administers Holy Communion to churches in Batam; Adults Fellowship mission trip to Batam.

November 6

Pastor Colin Wong administers Holy Communion to churches in Batam.

December 4

Pastor Charles Seet administers Holy Communion to churches in Batam; Free clinic for Batam Churches by Medical and Dental mission team.

If you would like to participate in any of these mission trips please contact the Missions Committee at missionscom@lifebpc.com for more information.

LIFE B-P CHURCH MISSIONS

Missionaries

Batam, Indonesia: Sis Roska Choi, Pr Efendi Ginting & his co-workers Sis Merry Lasfeto, Bro Mikdal Lisin and Sis Paola Simbolon

Kenya: Sis June Tan-Korir (on 3-months attachment to Batam)

Komponentsom, Cambodia: Rev David Koo and Rev Moses Hahn

Partners-in-Missions

Myanmar: Rev Andrew Kam

Chiang Mai, Thailand: Rev Nirand Tamee & Sis Jess Lim

On Study Leave

Sis Chan Pui Meng